

EchoSpan® LU80-84

Ultrasonic Liquid Level Transmitter



Application

The general purpose ultrasonic transmitter provides continuous level measurement up to 32.8' (10m) with a 4-20 mA signal output, and is configured via its integral push button display module. This non-contact liquid level sensor is well suited for corrosive, ultrapure, sticky or waste liquids, and is selected for bulk storage, tanker truck and neutralization tank applications.



Features

- Offered in 4 measurement ranges from 9.8' (3m) to 32.8' (10m)
- Configuration is simple via integral push button display module
- LCD display indicates level in inches, centimeters and percentages
- Narrow 2" or 3" beam width for applications with limited measurement space
- Fail-safe intelligence and diagnostic feedback for simple troubleshooting
- PVDF transducer and NEMA 4X polycarbonate enclosure for corrosive liquids
- Automatic temperature compensation for accurate measurement

Success

Thermoelectric power plants use tens of millions gallons of water per day in their steam turbines and cooling towers. As such, most US plants are located in the Coastal or upper Midwest states with easy access to abundant ocean or lake resources. These facilities have lots of sumps that collect and pump transfer water into treatment for reuse or release to the environment. But the sumps capture much more than water including grease, oil and chemicals that coat everything in the pit. Here, an EchoSpan ultrasonic level transmitter is installed over the sump man-way. The patented digital signal processing technology features an industry leading 3" beam width that enables installation in close proximity to the ladder and side wall.



Compatible Products



LI23

DATALOOP™

Level Indicator



LI55

DATAVIEW™

Level Controller

EchoSpan® LU80-84

Ultrasonic Liquid Level Transmitter



Specifications

Range:	LU80: 4" to 9.8' (10cm to 3m) LU81: 8" to 18.0' (20cm to 5.5m) LU83: 8" to 26.2' (20cm to 8m) LU84: 12" to 32.8' (30cm to 10m)
Accuracy:	± 0.2% of range
Resolution:	LU80: 0.019" (0.5mm) LU81/83: 0.039" (1mm) LU84: 0.078" (2mm)
Dead band:	LU80: 4" (10cm) LU81/83: 8" (20cm) LU84: 12" (30cm)
Beam width:	LU80: 2" (5cm) LU81/83/84: 3" (7.6cm)
Configuration:	Push button
Memory:	Non-volatile
Display type:	LCD, 6-digit
Display units:	Inch, cm and percent
Supply voltage:	12-28 VDC
Loop resist.:	500 Ohms @ 24 VDC
Signal output:	4-20 mA, two-wire
Signal invert:	4-20 mA, 20-4 mA
Signal fail-safe:	4mA, 20mA, 21mA, 22mA or hold last
Process temp.:	F: -7° to 140° C: -20° to 60°
Temp. comp.:	Automatic
Ambient temp.:	F: -40° to 160° C: -40° to 71°
Pressure:	MWP = 30 psi (2 bar)
Enclosure rating:	NEMA 4X (IP65)
Encl. material:	Polycarbonate
Encl. hardware:	Brass & stainless
Enclosure vent:	Water tight membrane
Conduit entrance:	Dual, 1/2" NPT
Trans. material:	PVDF
Process mount:	LU80: 1" NPT (1" G) LU81/83/84: 2" NPT (2" G)
Mount gasket:	Viton®
Classification:	General purpose
Compliance:	CE, RoHS

Dimensions

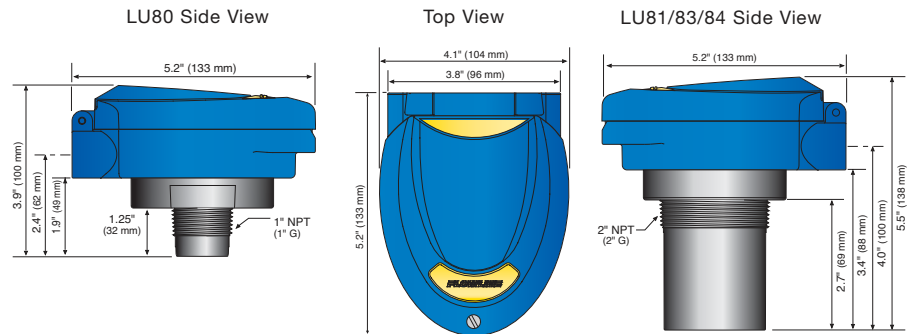

Fittings

For optimum performance, install the level sensor using the below recommended or direct equivalent fittings.

	P/N	DESCRIPTION
	LM52-1400	2" NPT x 1" NPT, PVC, schedule 40
	LM52-2400	3" NPT x 2" NPT, PVC, schedule 40
	LM52-2800	3" NPT x 2" NPT, PVC, schedule 80
	LM52-3800	4" NPT x 2" NPT, PVC, schedule 80
	LM52-1410	2" socket x 1" NPT, PVC, schedule 40
	LM52-2410	3" socket x 2" NPT, PVC, schedule 40
	LM52-3410	4" socket x 2" NPT, PVC, schedule 40
	LM52-2810	3" socket x 2" NPT, PVC, schedule 80
	LM52-3810	4" socket x 2" NPT, PVC, schedule 80
	LM52-2890	2" NPT bulkhead fitting, PVC
	LM50-1001-1	1" NPT side mount bracket, PP
	LM50-1001	2" NPT side mount bracket, PP

Ordering

	LU8	-51	1
SENSOR RANGE			
0	3m (9.8')		
1	5.5m (18.0')		
3	8m (26.2')		
4	10m (32.8')		
PROCESS MOUNT (1)			
0	NPT (US)		
6	G (Metric)		

NOTES

- 1) Install the level sensor using Flowline installation fittings or equivalents.